



BDN FASTENERS

**AS3566
Building Fasteners**

Made in Taiwan





ABOUT

- ◆ 3D Screw Modeling for Drawing Verification and Presentation
- ◆ Constant New Product Development
- ◆ Quality Guaranteed
- ◆ On-Time Delivery
- ◆ Competitive Pricing
- ◆ Efficient Customer Service
- ◆ Unique and Expressive Packaging Design



2009

Established in 2009 and began the trade of selling construction fasteners.

2014

BDN FASTENERS, the 100% made in Taiwan brand, steps into the fasteners scene.

2015

BDN FASTENERS Thailand was established in 2015, and set up as a base for sales and promotion of BDN Fasteners in ASEAN countries.

2017

BDN Fasteners takes a major step forward and builds a new facility dedicated to Heading, Threading, and Pinch Pointing processes - maximizing speed and efficiency, taking our service and quality to the next level.

2018

Despite hard times, BDN Fasteners takes yet another bold step forwards, relocating to a larger storage and packaging facility for better logistics, accommodate additional personnel, and new packaging machinery.

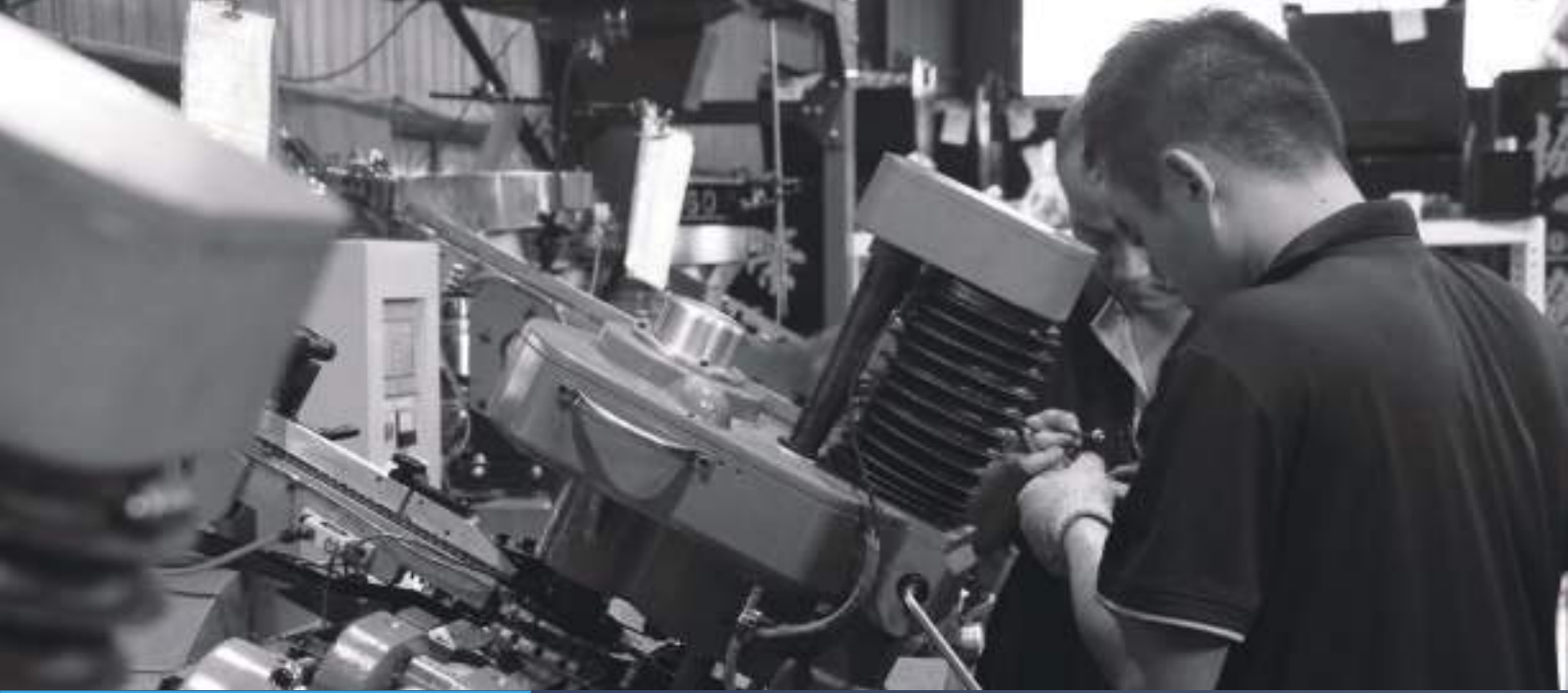

CONTENTS

METAL-Tite

VALLEY FIXING FASTENERS



01

CREST FIXING FASTENERS



02

STITCHING FASTENERS

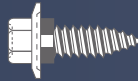

03

CONCEALED FIXING FASTENERS



04

TIMBER-Tite

VALLEY FIXING FASTENERS



05

CREST FIXING FASTENERS



06

POLYXPAND

SKYLIGHT FIXING FASTENERS

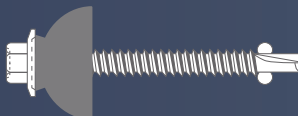

07

VALLEY FIXING FASTENERS

Carbon steel fasteners for fixing steel sheets into steel substrates

STEEL PENETRATION

Max 6.0mm thick (For #12 gauge)

ADAPTER TO USE

Magnetic Hex Socket (5/16")

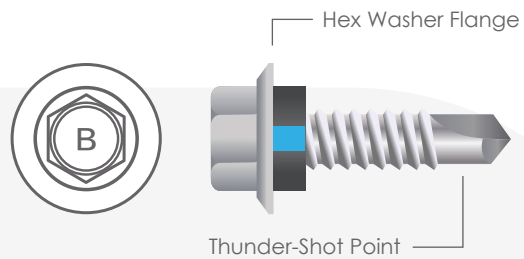
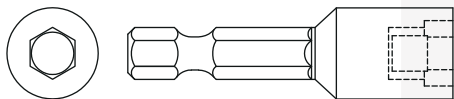

PRODUCT FEATURES

Hex Washer Flange
Thunder-Shot Point

WASHER

True Blue DEKS Blue Seal Washer

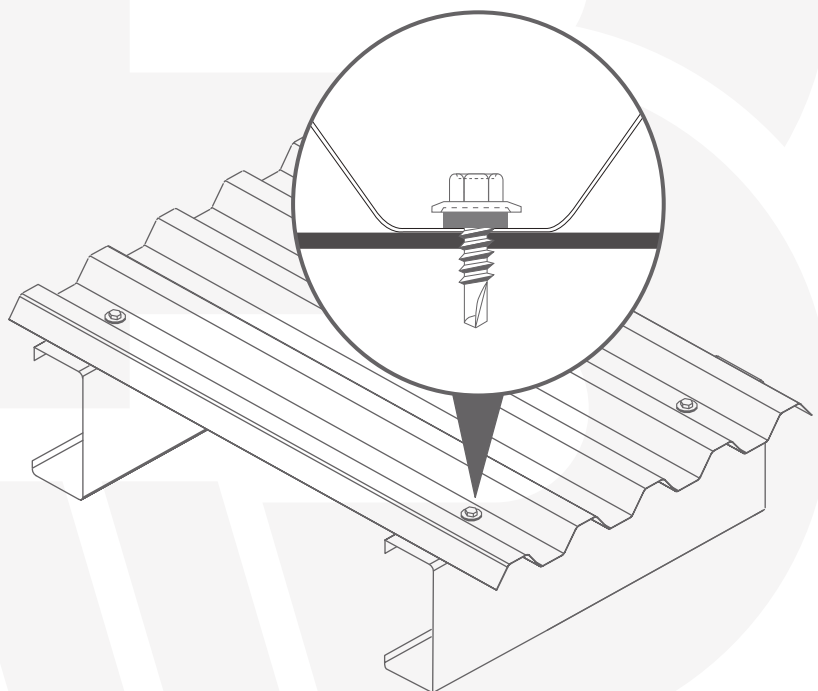

PART NUMBER

Silver

BS-SDHC1225C3N 12-14 x 25mm
BS-SDHC1235C3N 12-14 x 35mm

CREST FIXING FASTENERS

Carbon steel fasteners for fixing steel sheets into steel substrates

STEEL PENETRATION

Max 6.0mm thick (For #12 gauge)

ADAPTER TO USE

Magnetic Hex Socket (5/16")

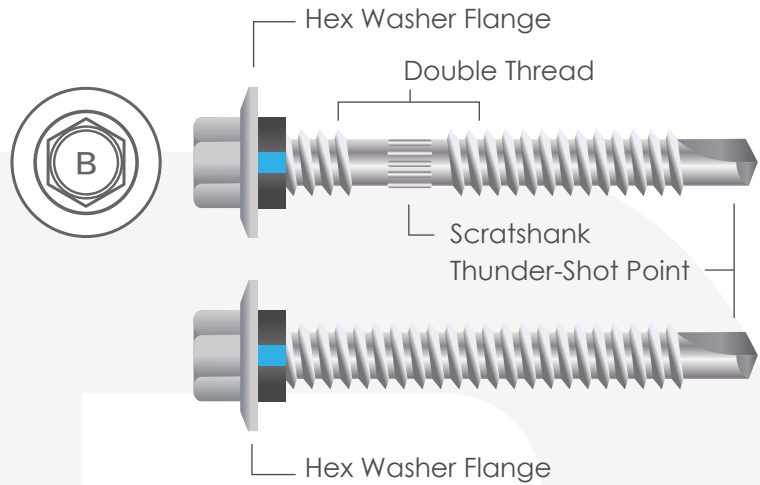
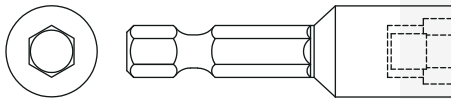

PRODUCT FEATURES

Hex Washer Flange
Thunder-Shot Point
Double Thread
Scratchank

WASHER

True Blue DEKS Blue Seal Washer

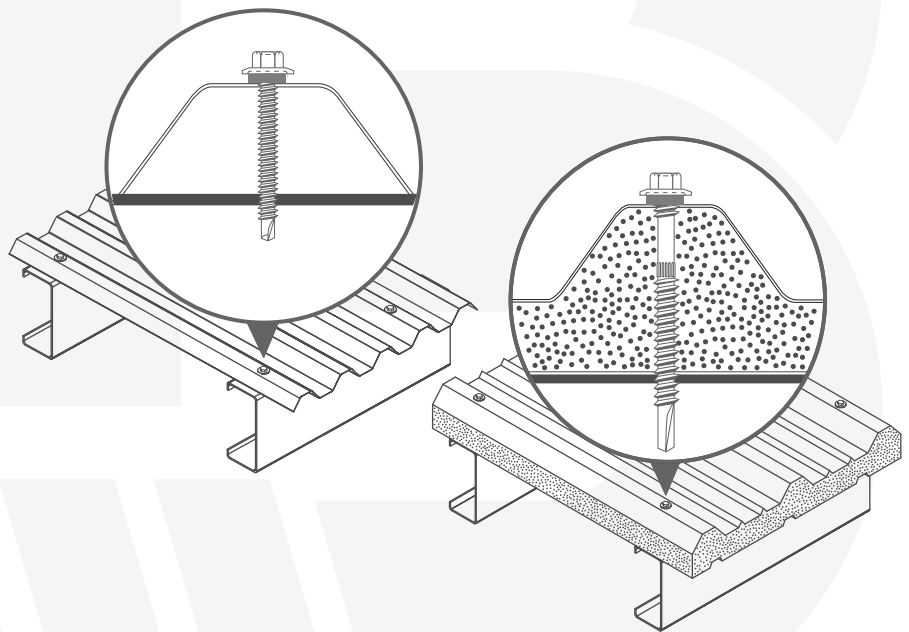

PART NUMBER

Silver

FULL THREAD

BS-SDHCG1245C3N	12-14 x 45mm
BS-SDHCG1255C3N	12-14 x 55mm
BS-SDHCG1265C3N	12-14 x 65mm
BS-SDHCG1275C3N	12-14 x 75mm

DOUBLE THREAD

BS-SDHC1245C3N	12-14 x 45mm
BS-SDHC1255C3N	12-14 x 55mm
BS-SDHC1265C3N	12-14 x 65mm
BS-SDHC1275C3N	12-14 x 75mm

*For size not indicated below, please contact for further information

STITCHING FASTENERS

Carbon steel fasteners for fixing steel sheets into steel substrates

STEEL PENETRATION

Max 1.0mm thick

ADAPTER TO USE

Magnetic Hex Socket (5/16")

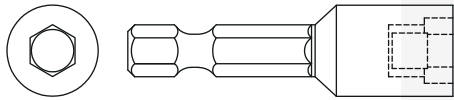

PRODUCT FEATURES

Hex Washer Flange

Needle Point

WASHER

True Blue DEKS Blue Seal Washer



PART NUMBER

Silver

BS-SDHST1019C3N 10-16 x 19mm

BS-SDHST1025C3N 10-16 x 25mm

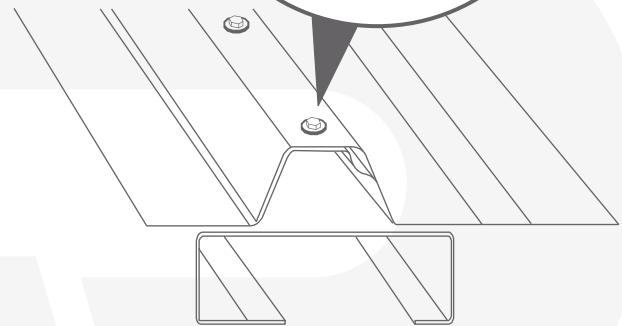
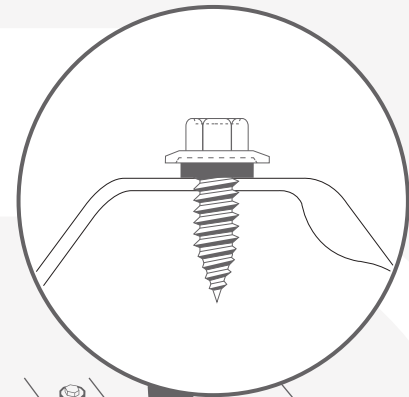
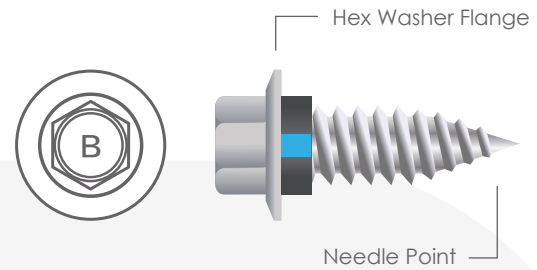

CONCEALED FIXING FASTENERS

Carbon steel fasteners for fixing steel sheets into steel substrates

STEEL PENETRATION

Max 4.0mm thick

ADAPTER TO USE

Philips Bit (PH2+)

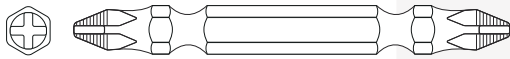

PRODUCT FEATURES

Wafer Head

Philips Drive

Thunder-Shot Point

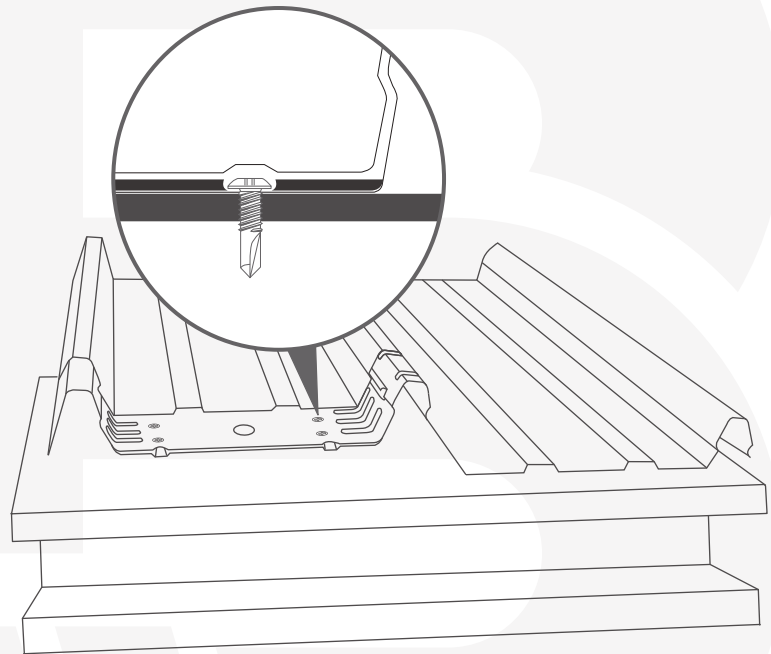
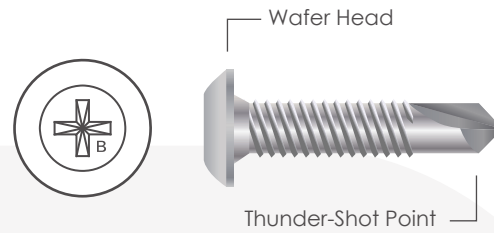

PART NUMBER

Silver

BS-SDWF1022C3 10-24 x 22mm

*For size not indicated below, please contact for further information

VALLEY FIXING FASTENERS

Carbon steel fasteners for fixing steel sheets into timber substrates

TIMBER PENETRATION

Min 20mm penetration

ADAPTER TO USE

Magnetic Hex Socket (5/16")

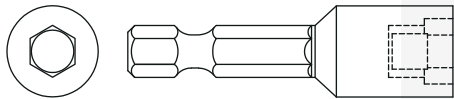

PRODUCT FEATURES

Hex Washer Flange

Type 17 Sharp Point

WASHER

True Blue DEKS Blue Seal Washer



PART NUMBER

Silver

BS-T17H1020C3N 10-12 x 20mm

BS-T17H1025C3N 10-12 x 25mm

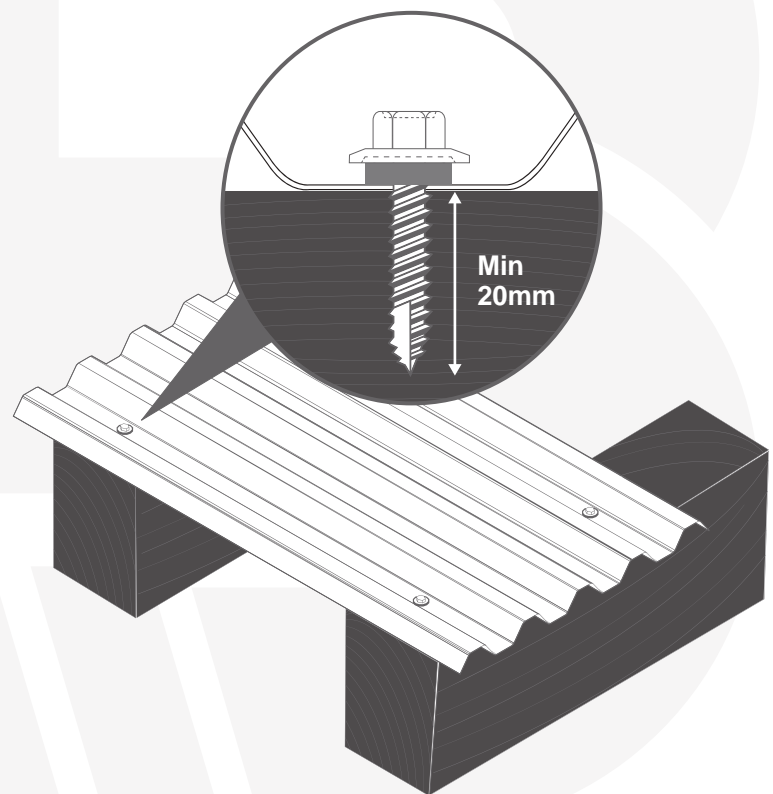
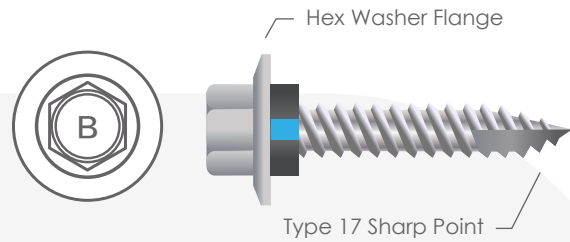

*For size not indicated below, please contact for further information

CREST FIXING FASTENERS

Carbon steel fasteners for fixing steel sheets into timber substrates

TIMBER PENETRATION

Min 25mm penetration

ADAPTER TO USE

Magnetic Hex Socket (5/16")

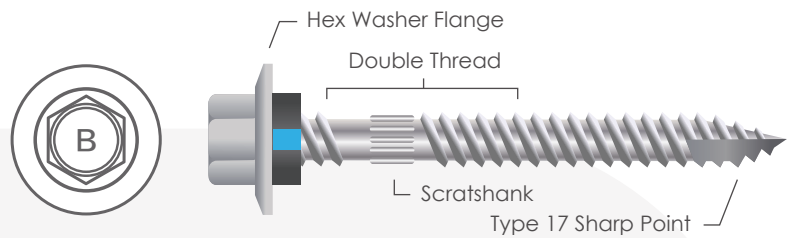
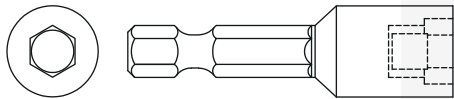

PRODUCT FEATURES

Hex Washer Flange
Type 17 Sharp Point
Double Thread
Scratchshank

WASHER

True Blue DEKS Blue Seal Washer

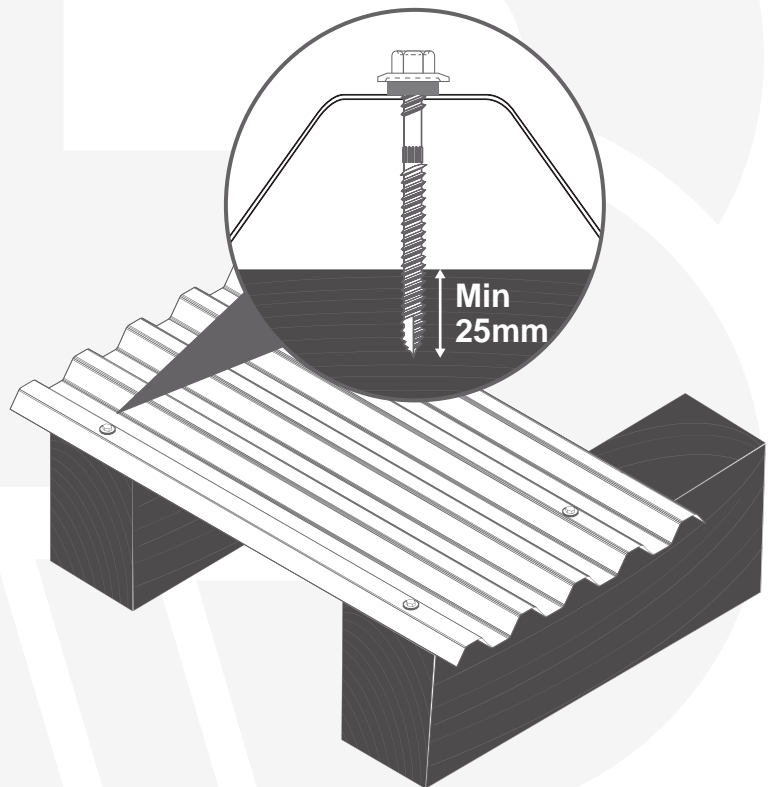

PART NUMBER

Silver

BS-T17HCG1255C3N 12-11 x 55mm

SKYLIGHT FIXING FASTENERS

Carbon steel fasteners for fixing skylight to steel substrates

STEEL PENETRATION

Max 5.5mm Thick

ADAPTER TO USE

Magnetic Hex Socket (5/16")

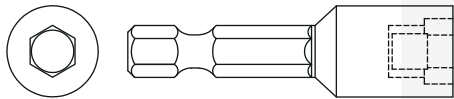

PRODUCT FEATURES

Hex Washer Flange
Expansion Wings
Thunder-Shot Point

WASHER

25mm Dome Grey EPDM



PART NUMBER

Silver

BS-SDHCP1255C3D 12-14 x 55mm

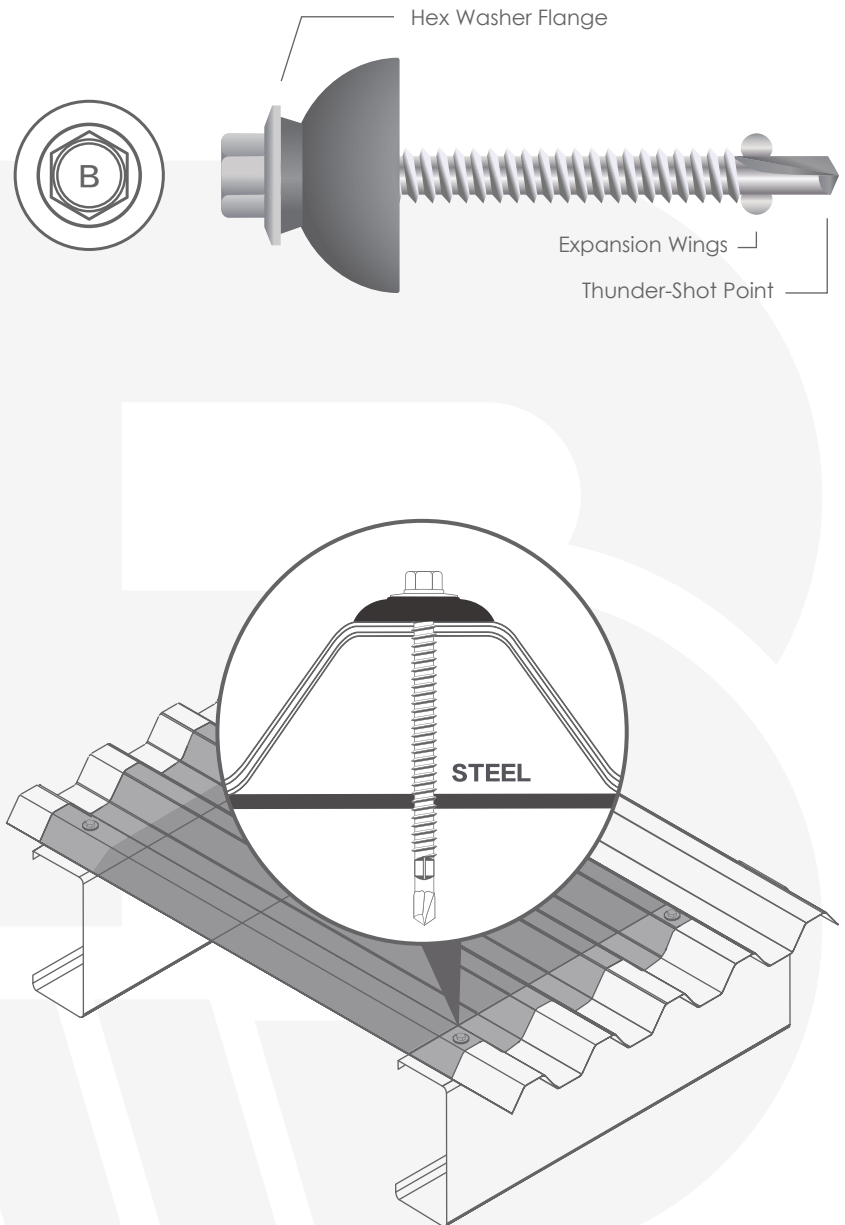

Roofing Screw Selection Chart

METAL-Tite

VALLEY FIXING FASTENERS

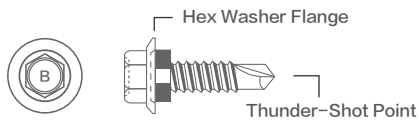

12-14 x 25mm
12-14 x 35mm

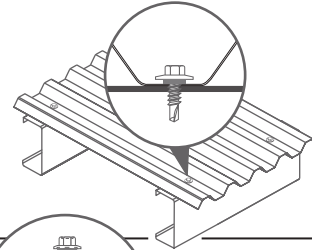

METAL-Tite

CREST FIXING FASTENERS

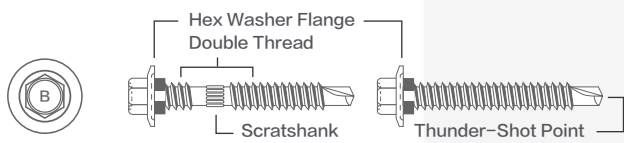

12-14 x 45mm
12-14 x 55mm
12-14 x 65mm
12-14 x 75mm

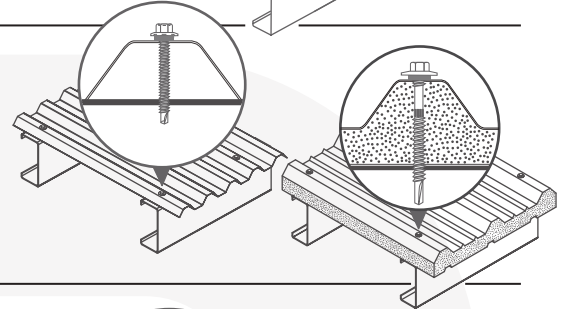

METAL-Tite

STITCHING FASTENERS

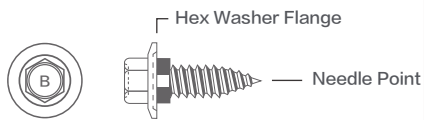

10-16 x 19mm
10-16 x 25mm

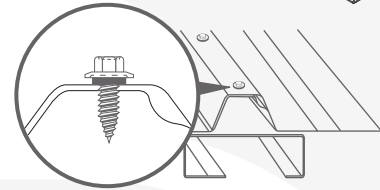

METAL-Tite

CONCEALED FIXING FASTENERS

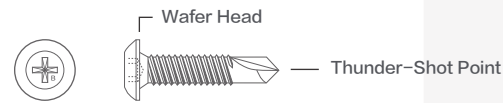

10-24 x 22mm

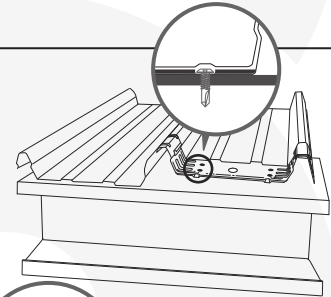

TIMBER-Tite

VALLEY FIXING FASTENERS

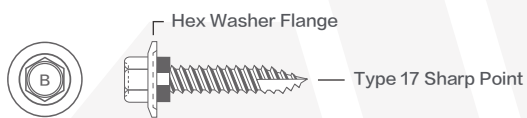

10-12 x 20mm
10-12 x 25mm

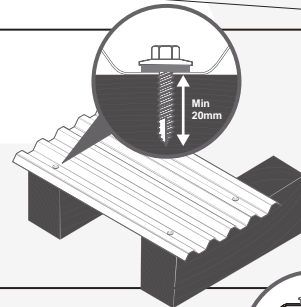

TIMBER-Tite

CREST FIXING FASTENERS

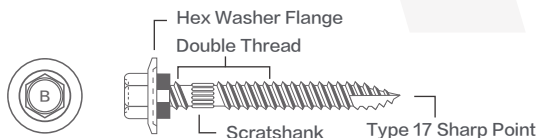

12-11 x 55mm

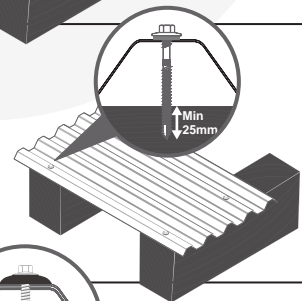

POLYXPAND

SKYLIGHT FIXING FASTENERS

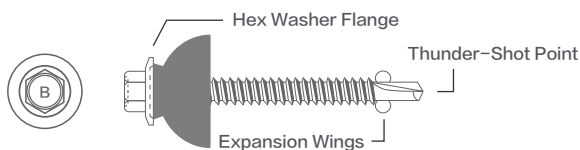

12-14 x 55mm

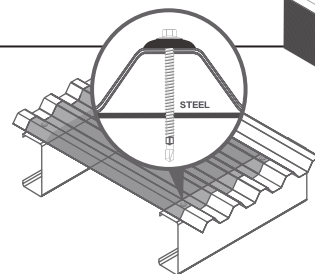

BDN FASTENERS® Coating

BDN FASTENERS® Coating

BDN FASTENERS® weathering resistant coating is what professional builders and DIY users demand when seeking protection against the elements for their fasteners but at an affordable price. B Series coating consists of specially formulated, corrosion resistant chemicals, and carefully arranged in multiple layers to prolong the lifespan of BDN Fasteners. Each layer of the B Series coating has been carefully contrived and thoroughly tested to ensure the final product not only complies with AS3566.2 (2002) standards, but in comparison, further excels in weathering resistance and performance.

BDN FASTENERS® B Series Coating versus AS 3566.2 (2002), Class 3

Parameters	Australian Standard AS 3566.2 (2002), Class 3	BDN Fasteners® Coating B Series
Accelerated Tests Neutral Salt Spray Test as per ASTM B117	1000 hours < 5% red rust	1,000 hours < 5% red rust
Accelerated Tests Kesternich Test (2.00 concentration of Sulphur Dioxide Exposure) as per DIN 50018 2.0 SFW	15 cycles < 5% red rust	15 cycles < 5% red rust
Coating Contents	Zinc = 70% — 75% or Tin = 25% — 30%,	Proprietary Coating of Aluminium / Zinc Alloy with Zinc Plating as base.
Coating Thickness	Mechanically plated to min. thickness of 25 µm	Average of 15 — 22 µm

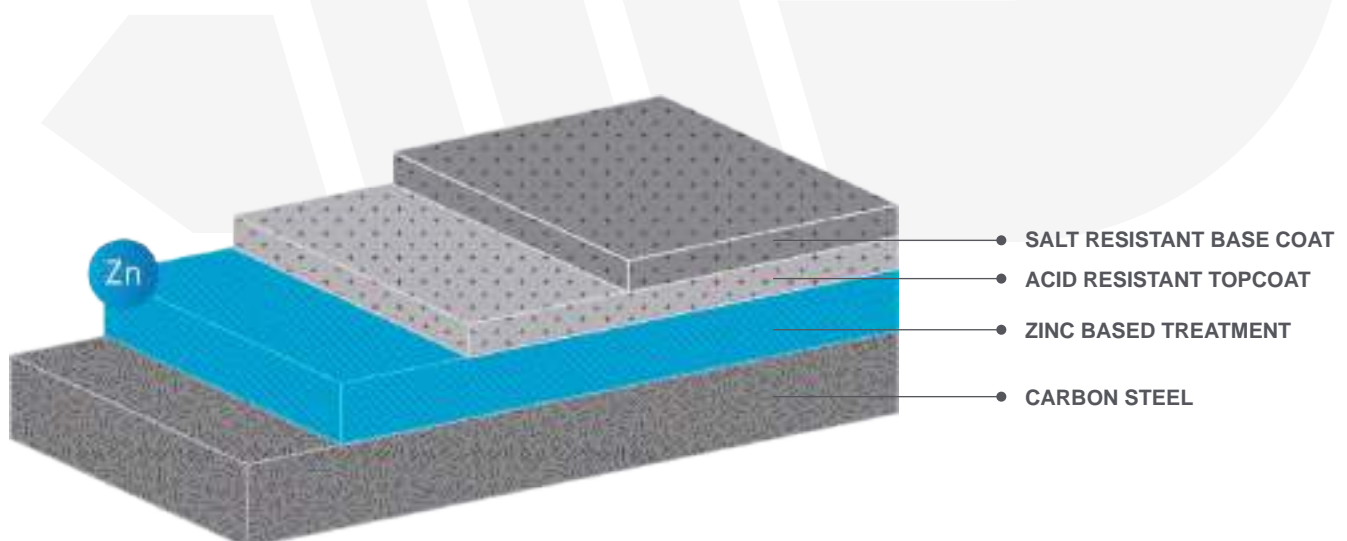

Packaging Guide

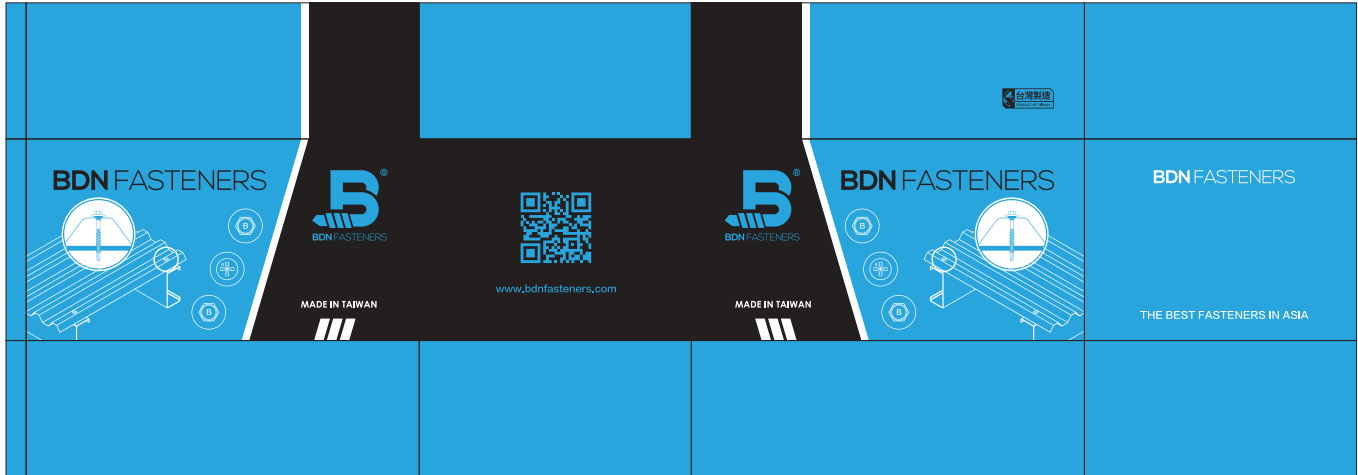

BDN FASTENERS product labels are always placed at the center of the box.

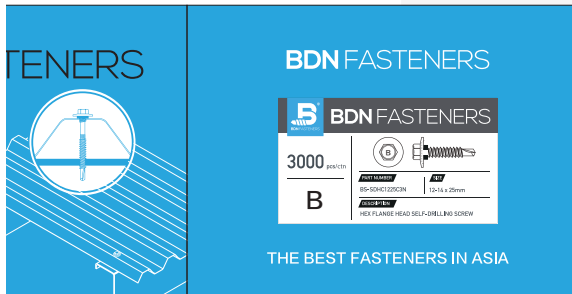

PRODUCT LABEL

BDN FASTENERS come with large, easy to read product labels. Each product has its own unique label showing the product category, packaged quantity, size, part no., color and description.

To re-order, quote the Part No., Product Description, and Color Code as indicated below. This information can be easily obtained from existing packaging.

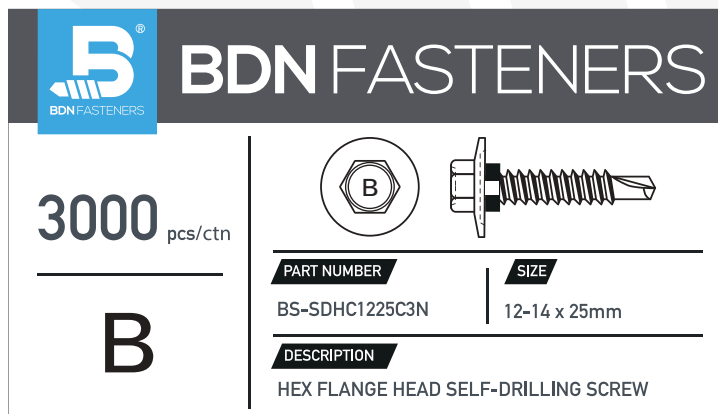

All BDN FASTENERS product labels must be placed at the designated area on the carton as stated below.

! DO NOT!

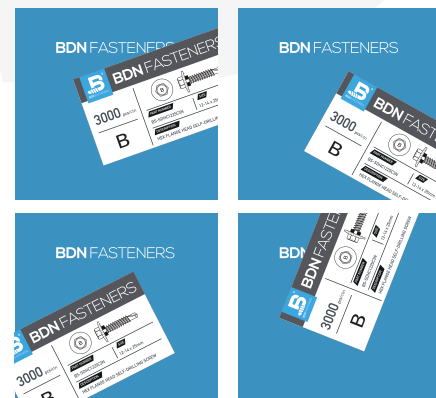



EAGLE ENGINEERING

No.457, 8th Cross, Laxmi Mico Layout,
Arekere Puttenahalli, BG Road,
Bengaluru, Karnataka - 560076

☎ 080-4095 2129 📞 96322 73178
✉ info@eagleeng.in 🌐 www.eagleeng.in

    /ieagleng